

10. Diagnostic system

10.1 Introduction

A synchrotron light source requires a diagnostic system to carry out its commissioning and maintain its design performance during normal conditions of operation.

Diagnostic devices must measure both machine and beam parameters under all modes of standard operations and, also, under abnormal conditions. The goal is that a stable photon beam within the nominal specifications, is guaranteed to be delivered to the users of. To this end various devices will be distributed around the accelerator. These devices, together with their signal processing electronics make up the diagnostic system. The diagnostic system, in summary, is needed to store the beam, to reach the desired performance and to keep the storage ring running efficiently.

10.2 Instrumentation

The Table (10.1) below summarises standard devices used for diagnostics at synchrotron sources and indicates their functions.

Table 10.1: Diagnostic devices and their use

Diagnostic device	Functions
Faraday cup	Beam charge and time structure in transfer lines
Fluorescent screen	Transverse profile and position
DC Current Transformer	Average beam intensity and beam lifetime
Fast Current Transformer	Observing short beam pulses in transfer lines
Integrating Current Transformer	Charge in a pulse in transfer lines.
Beam Position Monitor	Transverse Position, closed orbit and tune measurement
Stripline	Position, beam spectra and tune measurement
Scraper	Dynamic aperture and beam profile
Beam loss monitor	To minimize radiation level
Photon monitors, CCD camera	Transverse distributions, position and emittance.
Streak camera	Bunch shape and beam instabilities

Some of these devices are used to obtain, directly or indirectly, more than one parameter and also, a given parameter may be recorded by more than one instrument or a combination of several of them.

10.3 Measurement Procedures

The recording of the beam position and current is a typical function of the diagnostic system. The knowledge of these parameters is essential in the injection and storage of the electron beam. In addition the recording of the longitudinal and transverse distributions of the beam (i.e. transverse beam size and profile, bunch length, energy spread) is a requirement during the commissioning of the accelerator.

10.3.1 Beam Intensity and Time Structure

Several types of devices should be installed around the accelerator complex for the monitoring and recording of electron beam currents. A Faraday Cup is used to measure the total charge from the pre-injector. With this destructive device the beam charge is collected by an electrode. This type of system is relatively simple and sensitive but it can operate only at low energies and currents.

The DC component of the stored beam will be measured with a high precision DC current transformer. DCCTs detect the magnetic field induced by the moving charges onto its core, and provide an absolute measurement of the average beam current. To record the current circulating in the booster one has less stringent requirements and, therefore, there we will use a cheaper device such as a modular parametric current transformer. Current Transformers are integrated to measure non-destructively the charges of circulating electrons in the transfer lines and the booster. Finally, the non-destructive recording of the longitudinal beam profiles in the transfer lines will be achieved with Fast Current Transformers with very short rise time.

We note that in all cases these devices have to be installed in straight sections, preferably well away from magnet end-fields, where a ceramic break in the vacuum chamber must be installed, and a carefully-designed magnetic and RF shield must be provided.

Monitoring beam currents at appropriate positions in the accelerators complex provides measurement of the injection efficiency. Upon completion of injection and stable beam storage, it is straightforward to monitor its lifetime from the history display of the stored beam current. In practice, this is the most immediate performance indicator of the storage ring.

10.3.2 Beam Position

During machine commissioning, a quick and straightforward way of determining the presence of the beam is needed. To this end the simplest and most reliable way is to intercept the electron beam. Several retractable fluorescent screens and CCD cameras, placed at different positions along the trajectory will be used to provide a direct visualisation of beam position, transverse distribution of particles and intensity. Fluorescent screens are also especially useful to get fast qualitative information from single beam shots, as it is the case in the transfer lines or during the first turn. Screens are driven by stepper motors, which are controlled by the main control system. A TV monitor in the control room displays the beam image formed on the scintillator.

The use of button-type electrodes currently constitutes the standard non-destructive way of measuring the transverse position of the circulating electron beam during steady state operation. Many of these Beam Position Monitors (BPM) will be distributed around the accelerators. Each BPM consists of four button pickups (PU) capacitively coupled to the beam. They must be positioned within housing recesses in the vacuum chamber and placed well away from the horizontal plane so that they do not significantly change the electrical impedance of the chamber and to avoid that synchrotron light streaks the PUs.

10.3.3 Transverse and Longitudinal Particle Distribution

The emitted synchrotron light may be used as a powerful non-destructive diagnostic tool. The visible light emitted from a bending magnet is collected and focused in an optical bench. A common CCD camera will be used to record the transversal size and shape of the electron source. From this measurement the transverse electron beam distribution can be extracted and in addition, beam stability can be assessed and the instantaneous value of beam emittance, brilliance and photon flux density inferred.

Other complementary ways to determine these parameters will also have to be installed. These will consist of one horizontal and one pair vertical scrapers, which will define the outer edges and electron density of the beam. In addition, a pickup electrode with appropriate signal amplification and fast data recording can be used to obtain measurements of the bunch length.

10.3.4 Lattice Functions, Tune and Dynamic Aperture

With regards to the determination and subsequent optimization of the lattice functions (i.e. the beta functions and dispersion), measurements of the beam characteristics at the position of the diagnostic devices described above will be used to extract the lattice functions, upon activation of a kicker, which perturbs the beam trajectory. The optimization will be carried out by means of an

iterative process involving the settings of all the magnetic elements until the lattice functions extracted from the measurements converge on the predicted ones.

Regarding the tune of the machine, the approach will rely on measuring the response of the beam to an applied excitation. Striplines, fast kickers or traveling wave electrodes could be used to excite the beam transversally. Longitudinally, the excitation is achieved for example, by phase modulation of the cavity voltage. The resulting beam oscillations will then be observed in frequency domain with a network analyzer connected to a pickup electrode and the tune work out.

With regards to the dynamic or physical aperture, we will drive a scraper so that the beam is intercepted and then by monitoring the lifetime as a function of the position of the scraper, the aperture is easily determined.

10.3.5 Measurement of Other Accelerator Parameters

Regarding to radiation losses, these can be monitored with the aid of Beam Loss Monitors (BLM). These are commercially available radiation detectors, mounted onto the outside of the vacuum chambers, which must be installed at the inner side of the ring circumference, to indicate whether, when and where the beam (or part of it) is lost. In addition to locating points where beam losses may occur, BLMs are used to check the radiation levels around the accelerator.

Many other parameters will be measured to improve the performance of the accelerator facility. Chromaticity, coupling, tune shift, coherent oscillations, diagnostics of instabilities, strength of magnets, response matrix, non-linear resonances, vacuum chamber impedance are some of them. There are many ways of getting them by using the equipments listed above.

10.4 Diagnostic System of SESAME

The diagnostic elements proposed for the storage ring SESAME are given in the Figure (10.1) A detailed description is given in the following.

10.4.1 Fluorescent Screens

Fluorescent screens will be useful to control the injection process. For that purpose there will be one just after the septum magnet to check the incoming beam; one at the end of the injection bump to check that the bump is really a closed bump; and others more or less every quarter of the accelerator to check for the first complete orbit. Overall there are 6 screens in the storage ring.

10.4.2 Current Transformer

A DCCT current transformer will be installed to monitor the beam current. It will allow obtaining the injection efficiency and the lifetime of the stored beam. It will be installed in the diagnostic straight section.

10.4.3 Strip Lines

Two strip lines will be installed. For the tune measurement, one will serve as an exciter of the beam and the other as receiver of the excitation, allowing the determination of the horizontal and vertical tunes. The strip line will be used as well to pick up the spectrum of the beam and to find out the instabilities of the beam.

10.4.4 Scrapers

Two scrapers, one in the horizontal and the other in the vertical plane, will be installed. They are moved inside the vacuum chamber by a stepper motor in order to intercept the beam or to reduce the physical aperture. The beam profile and the dynamic acceptance can in this way be obtained. One scraper will be installed in the diagnostic straight section and the other at a position to have maximum amplitude.

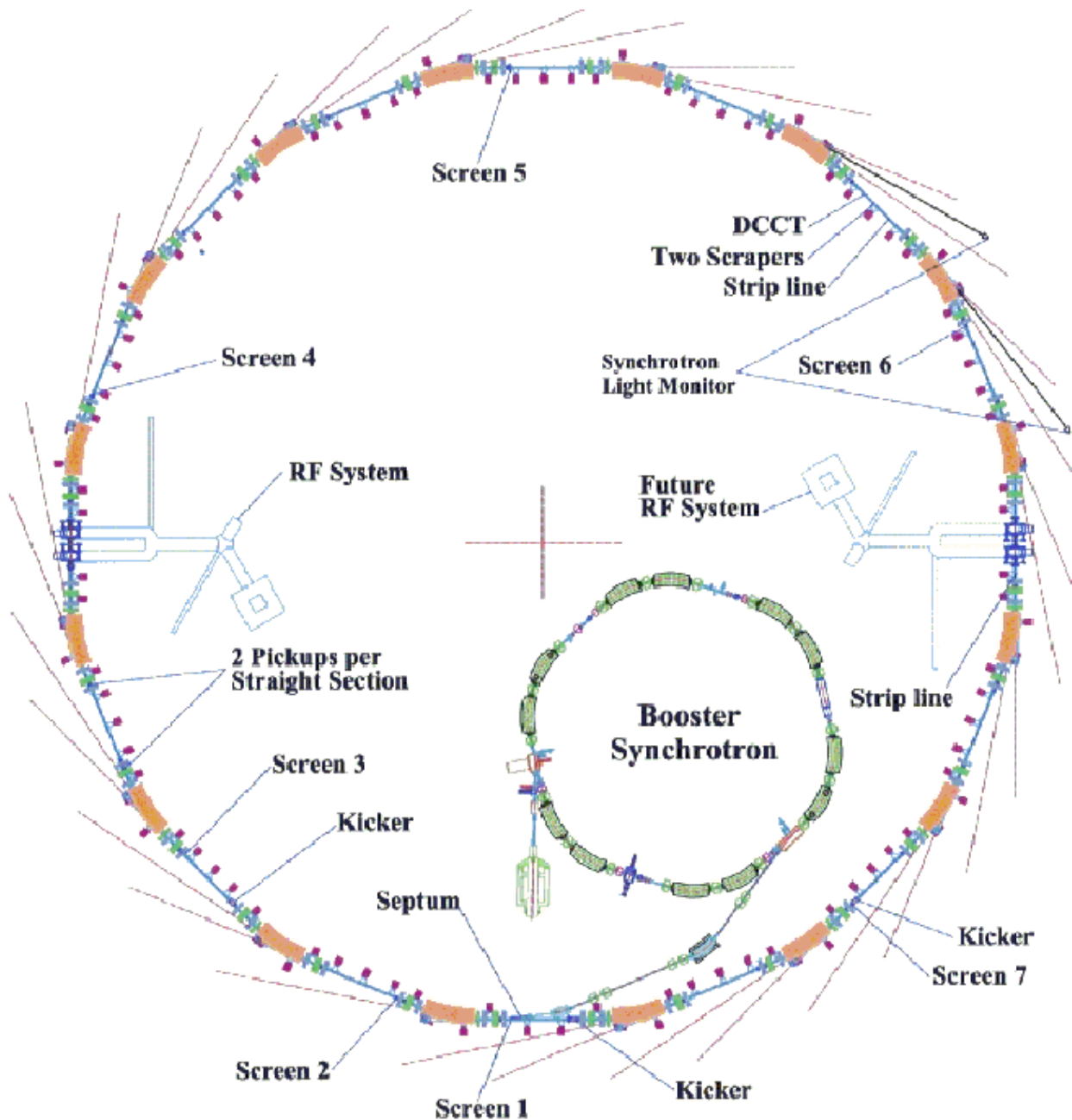

Figure 10.1: The layout of the storage ring SESAME with the proposed diagnostic elements

10.4.5 Beam Position Monitors

Transverse position measurements of the electron beam are needed both during commissioning and running. This information is obtained by a set of BPMs, which in addition to determining the position, are used to derive information concerning lattice functions and beam dynamics. Furthermore, the operation of the feedback system, with which the beam orbit is corrected if and when needed, also relies on the information provided by the BPM's. The cross section of the vacuum chamber with the position of the BPM's and the distribution of the electrical field from the bunch charge is presented in Figure (10.2).

There will be four BPMs in each cell of the storage ring, 32 in total. They will be placed at the exit and the entrance of each bending magnet and close to the quadrupoles. As a thumb rule there should be 4 BPM's per betatron oscillation. With a tune of 7 we need at least 28, which is with 32 fulfilled.

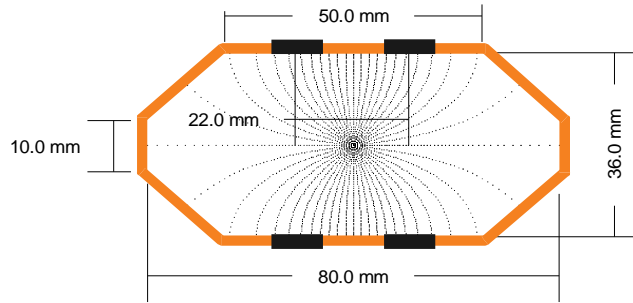

Figure10.2: Beam position monitor and the field created by a centered beam

10.4.6 Synchrotron Light Monitors

There will be three synchrotron light monitors using the visible part of the synchrotron radiation emitted by the bending magnets. One will be placed in a low dispersion section; the other in a high dispersion one, in this way the effect of the energy spread on the beam size could be inferred. The third one will be equipped with a photon multiplier. This will provide very useful information for the first tens of turns during commissioning and about the time structure of the beam during normal operation.

10.4.7 Other Instrumentation

All the information from the diagnostic devices goes to the control room, which will have to be equipped with the appropriate computer interface equipments as well as general-purpose instrumentation. The latter are commercial instruments like good quality oscilloscopes for the display of beam position signals, TV monitors for observing the synchrotron light image and the response of scintillators to the electron beam, a network and a frequency spectrum analyser for measuring the fractional part of the tune or to study the performance of the RF accelerating cavity, waveform generators, fast transient recorders, etc.