

# GENERAL STATUS OF SESAME

A. Nadji, T. Abu-Hanieh, M. Alnajdawi, A. Aladwan, A. Amro, M. Attal, D. Foudeh, A. Hamad, A. Kaftoosian, T. Khan, F. Makahleh, S. Matalgah, M. Shehab, H. Tarawneh, S. Varnasseri  
SESAME, P. O. Box 7, Allan 19252, Jordan

## Abstract

SESAME is a 3<sup>rd</sup> generation synchrotron light source facility under construction in Allan, Jordan, 30 km North-West of Amman. The building has been handed over on December 2007 and the main Microtron subsystems have been successfully tested. In the meantime, preparations of technical specifications for most of the storage ring subsystems are in progress. In this paper we will report on the progress of the Microtron, the conceptual design of the storage ring's bending magnet, RF system, shielding wall, cooling system and the service area implementation.

## INTRODUCTION

SESAME (Synchrotron-light for Experimental Science and Applications in the Middle East) will be the first international synchrotron light source in the Middle East region. It will promote peace and understanding through scientific cooperation. As of January 2008, members of the SESAME Council are Bahrain, Cyprus, Egypt, Iran, Israel, Jordan, Pakistan, Palestine Authority, and Turkey. A Director, Scientific Director, Technical Director and Administrative Director are on board and an accelerator group of 20 people is finalizing the design and the facility. The Phase I scientific program has been finalized and it foresees 7 beamlines from IR to hard X-rays. The injector complex of the facility consists of a 22.5 MeV Microtron and 800 MeV Booster. It is the one already used in Bessy I [1], with new power supplies, vacuum pumps and control system. The 2.5 GeV main Storage Ring (SR) is completely new. The beam emittance is 26 nm.rad and 12 straight sections are available for Insertion Devices. First photon beam is foreseen by the end of 2011.

## MICROTRON STATUS

The Microtron is being tested without beam in a hangar close to the experimental hall. The modulator, the magnet and its power supply have been tested and operated temporarily. The test and measured data showed us the good functionality of these subsystems. We concluded the validity of the whole Microtron system to be used as a pre-injector for SESAME machine. The figure 1 shows the Microtron during the tests.



Figure 1: SESAME Microtron under test.

The modulator test has been done by connecting its electronic circuits using external power supplies to satisfy the needed interlock conditions. Then we started the high voltage test with just the Magnetron PFN circuit connected (i.e. half modulator load). The amplitude of the 4- $\mu$ s voltage pulse from the modulator has been increased step by step (at vacuum pressure of  $4 \cdot 10^{-5}$  mbar) till we reached the operation voltage of 9kV as shown by figure 2. This pulse is transformed to 45kV pulse by the Magnetron transformer before being fed to Magnetron. We operated the modulator at 1 to 10Hz repetition frequency. The 10Hz mode showed the best performance.

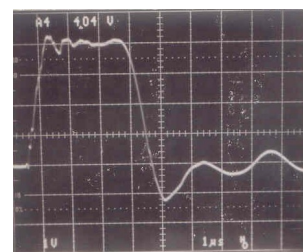

Figure 2: The modulator pulse current that we measured (left) compared to the one measured at BESSY I in 1998(right).

Main magnet measurement using a DTM-151 Digital Tesla Meter with  $\sim 3$ m long probe has been performed. The expected value of 0.1121T has been reached. The power supply had a good functionality and the magnetic field distribution uniformity was satisfactory. The maximum relative field error was  $\Delta B/B = 1.1 \cdot 10^{-3}$ .

The cooling circuits showed a good tightness under enough pressure. Using a 500L/s and 100L/s turbo pumps we could reach  $7 \cdot 10^{-6}$  mbar within 3days, taking into account that another 500L/s pump, in principle, is needed to reach the needed pressure of  $1 \cdot 10^{-6}$  mbar.

The Microtron Control system will be completely renewed; the renewal process will follow a gradual but comprehensive approach. First we will start with an upgrade of the old PLC that manages the interlocks and basic operation, a new PLC – Siemens S7 300 - that provides the same functionality will be provided. Later on, new signals and subsystems will be upgraded to provide compatible interface to the Control System based on industrial embedded systems that runs EPICS. Finally, all of these systems will be part of the global control system in such a way that allows controlling the Microtron from the control system. At the global scale, the plans are to utilize EPICS, VME's – only when needed - and embedded controllers running EPICS.

Refurbishment and installation of the Microtron in the experimental hall are to be started in July 2008.

## SR MAGNET-GIRDER ASSEMBLY

SESAME SR magnet system consists of 16 bending magnets, 32 focusing quadrupoles (QF), 32 defocusing quadrupoles (QD) and 64 sextupole magnets divided into two families, 32 SF and 32 SD [2]. The design of the bending magnet has been optimized in order to reduce the level of the flux density in the magnet yoke and the size of the lamina. With the new design 3.6% iron loss and 10% less size than the previous design [3] have been achieved, see Fig. 3.

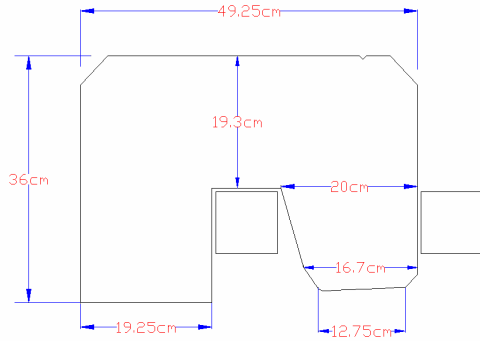

Figure 3: SESAME bending magnet lamina.

The quadrupole magnets, QF & QD, at SESAME will have the same pole profile but with different yoke length [2]. The 2D & 3D magnetic calculations have been finalized fulfilling the field quality requirements.

The magnetic calculation of the sextupole magnets, SF & SD, has been finalized. The SF and SD magnets are identical in pole profile and length [2]. Due to space shortage the horizontal (vertical) corrector are embedded in all sextupole SF (SD) and the study for the effect of the systematic higher order multipole driven by the correction coils on the dynamic aperture is in progress.

The SESAME girder system design consists of one type in which the girder pad which carries the dipole, 4 quadrupoles and 4 sextupoles is supported by three pedestals as shown in Fig. 4. The girder concept depends on a precise machined pad surface which allows the magnets to be placed and aligned easily.

Girder to girder alignment then carried out utilizing three vertical jacks and three struts system, one on the beam direction and the other two on a right angle to the beam direction on the horizontal plane.

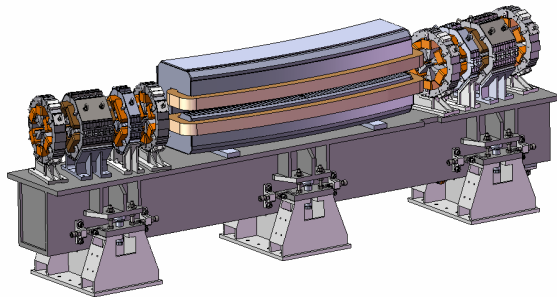

Figure 4: Half cell SESAME magnet-girder assembly.

FEA modal has been carried out to figure the natural frequencies of the girder magnet assembly. The first natural frequency founded to be 44Hz in which the dipole rocks about the beam direction. The higher mode frequencies start at 66Hz and correspond to the multipole magnets.

## SR RF SYSTEM

The SESAME accelerator complex consists of a Microtron, a booster synchrotron and a main storage ring. Each accelerator has its own RF system: all the RF systems are driven or controlled by a master RF oscillator (see Fig5). The Microtron RF system with 2MW peak power has been installed and tested in the system with 3GHz existing cavity and it is functioning properly.

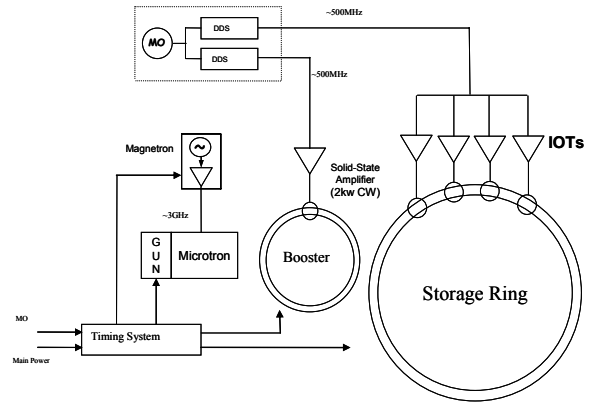

Figure5: Block diagram of SESAME RF system

The booster RF system has three major subsystems: a 500 MHz DORIS type cavity, a 2kW solid state RF amplifier, and low level electronics. The cavity has been conditioned at BESSYII and is ready to ship, while the low level electronics rack is available at SESAME and needs refurbishment and testing. The 2kW solid state RF amplifier has been ordered.

For the storage ring, the system is based on using four ELETTRA type RF cavities; each one will be fed by an 80kW IOT RF transmitter, planning to increase RF power up to 130 kW for each cavity in the second phase. We are also investigating the performance of the newly developed EU HOM damped cavity especially on its power handling capability. This cavity is an attractive alternative in relation to the suppression of longitudinal and transverse multibunch instabilities driven by HOM's of the RF cavities.

The updated RF parameters of SESAME storage ring are summarized in table 1.

Table 1. SESAME Storage Ring RF parameters

Frequency [MHz]	499.654
Harmonic number	222
Maximum peak voltage [MV]	2.4
Maximum current [mA]	400
Number of cavities	4

## DESIGN OF COOLING SYSTEM

SESAME cooling system consists of two subsystems; water cooling for machine components (magnets, RF cavities, absorbers, front ends, mirrors and power supply), air conditioning system for SR tunnel and experimental hall. Three chillers of 1MW capacity are used to generate chilled water at 10 °C that circulated through plate heat exchangers to produce cooled De Ionized Water (DIW) at 24 °C to cool down machine components. The system was designed for maximum current of 400 mA, energy of 2.5 GeV and allow for future modifications. Four water circuits are foreseen; booster circuit, storage ring circuit, RF and power supply circuit and beam line circuit. Water supply temperature is controlled as tight as  $\pm 0.5$  °C by mean of Direct Digital Controllers DDCs distributed inside technical building and experimental hall. DIW water is filtered and conditioned to provide minimum resistivity of 3 M $\Omega$ -cm and maximum particle size of 0.5 micron. Most components interlocked on water flow and temperature. The system will be implemented in two phases: first, installation of chillers, pumps in technical building, and experimental hall AHUs, second, installation of RF, SR and Booster water circuits in addition to SR tunnel AHUS. Full design of first phase and conceptual design for phase2 are prepared and will be reviewed very soon by experts from many light sources from Europe and USA.

## SERVICE AREA

The general layout of SESAME building and machine is presented in figure 6. The Experimental Hall (EH) is a steel structure 60m\*60m covered with a 8 tonnes crane. In addition, a two store annex (7.5m\*70m) have been added around for labs, offices, workshops etc. SESAME machine is located in the EH with 5m out of center and shifted towards the service entrance, hence, longer beam lines can be achieved (~36.7 m) and save entrance to enable us to unload SESAME equipment using 8 tonnes forklift and indoor 8 tonnes crane.

The locations of all cabinets (RF equipment, power supplies, pulsed magnet, BD, control and vacuum) have been finalized inside the service area. A raised floor is foreseen for easy access above water pipes and cables that comes from the technical building. All water pipes and electrical cables are supported under a bridge that connecting the 2<sup>nd</sup> floor of the annex near the control room crossing the EH over the roof of the shielding wall coming down with a stairs to the service area. Another access ladder is added to serve the ground floor.

## RADIATION SHIELDING

At SESAME the ALARA principle is applied by guaranteeing the radiation limits for non-exposed workers

(1mSv/y, corresponding to 0.5 $\mu$ Sv/h, for 2000 working hours per year). The determination of the thicknesses of the shielding walls all around the facility are based on conservative assumptions, including several modes of operations that involve normal beam loss mechanism as well as certain abnormal beam loss scenarios. These situations are drawn from experience and assumptions used at existing accelerator and synchrotron radiation facility. The pre cast shielding walls for the Microtron are now in progress.

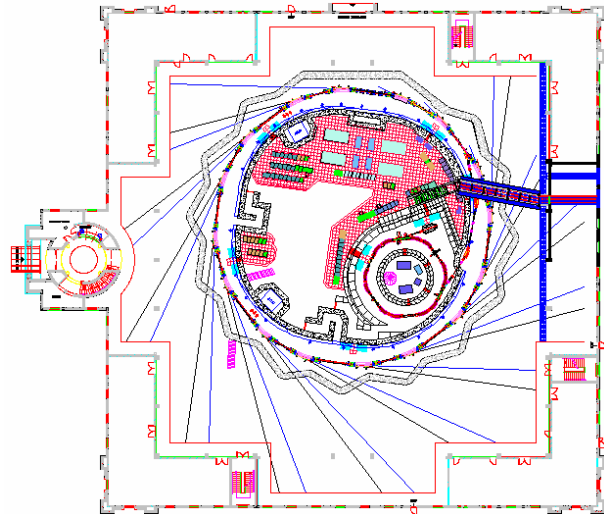

Figure 6: SESAME layout in the experimental hall.

## IN PROGRESS

The inventory of the Booster equipment has been done and the call for tender for the Booster power supplies has been sent. A detailed study of the SR pulsed injection system has been performed and it is published in this conference [4]. Controls, Diagnostics, Vacuum and RF laboratories are being equipped, in addition to a mechanical workshop. The preparation of the alignment and survey is going on. More staff has to be hired this year especially in electrical, electronics and controls areas. A strong collaboration is made with many laboratories like SOLEIL, ALBA, SLS, BESSYII and expected with ELETTRA and APS.

## REFERENCES

- [1] SESAME Green Book, October 1999.
- [2] G. Vignola, M. Attal, "SESAME Lattice", Technical Note: O-1, December 21, 2004, Amman, Jordan.
- [3] S. Varnasseri, "Dipole Magnet Design for SESAME", Note-M-1, Amman, Aug. 2005.
- [4] S. Varnasseri et al., "Finalized design of the pulsed magnets and their PS for SESAME ring injection", these proceedings.